

# New!

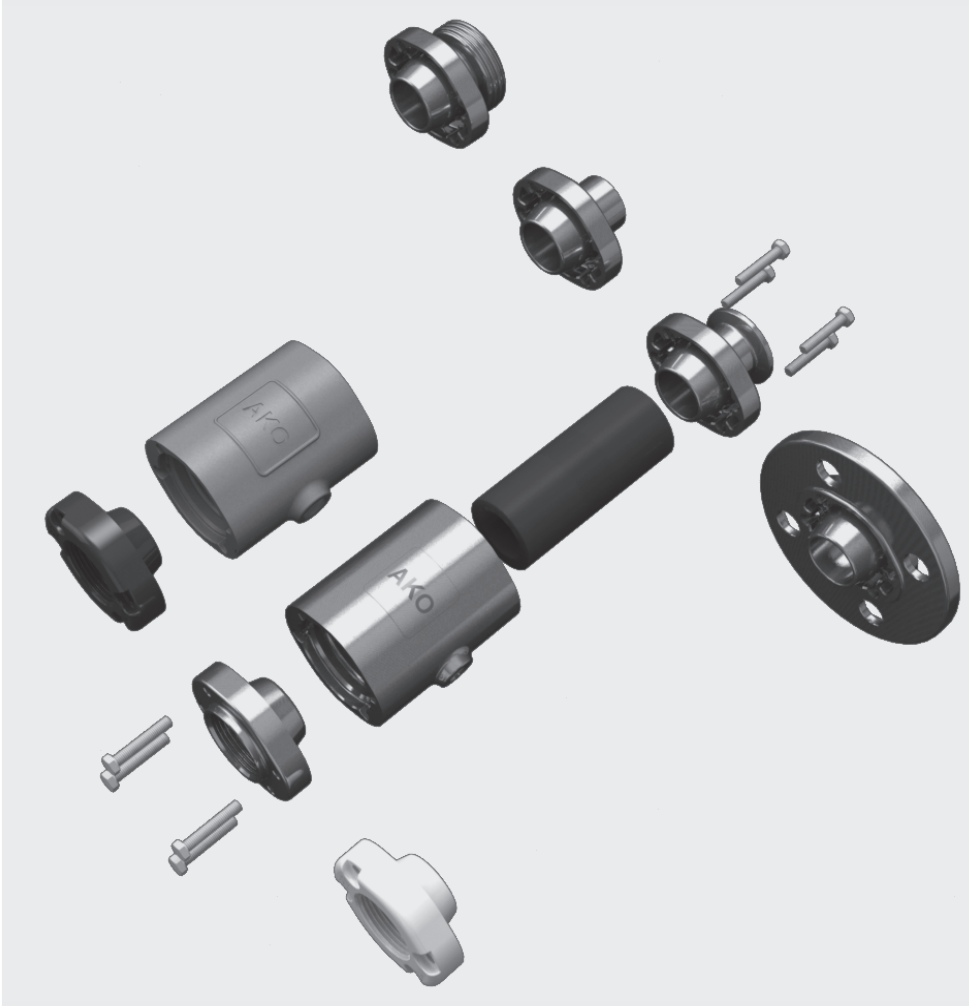

## Pnömatik pinç vanaları tip VMC

## Air operated Pinch Valve type VMC



Flanş / Flange



İç dişli bağlantısı / Internal Thread



Tri-klamp / Tri-Clamp



Kaynak uçları / Weld-on ends



Vida dişli ağız / Threaded spigot

### ▲ Çözülebilir ve aseptik boru hattı bağlantıları için esnek modüler sistem!

Her tür katı maddeyi, süspansiyonu, macunu, gaz biçiminde ve kıvamlı ortamları geri tutmanın ve ayarlamının en ideal çözümü.

#### Tercihler:

- Esnek modüler sistem
- Çeşitli bağlantı seçenekleri
- Son derece kompakt
- Düşük ağırlık
- %100 serbest ürün akışı
- Ölü bölge yok
- Kolay manşet değiştirme
- Optimum sızdırmazlık
- Hesaplı

### ▲ The flexible modular system for solvable and aseptic piping connections!

The ideal solution for isolation and regulation of solids of all kinds, suspensions, pastes, gaseous, fibrous and viscous media.

#### Advantages:

- Flexible modular system
- Various connection options
- Extremely compact
- Light weight
- Complete free passage
- No dead spots
- Easy maintenance and re-sleeving
- 100% tight shut off
- Competitive

# Pnömatik pinç vanaları tip VMC

## Air operated Pinch Valve type VMC

### Endüstri alanları:

- Gıda / İlaç endüstrisi
- Kimya endüstrisi
- Pnömatik konveyör sistemleri
- Pigment / Granül işleme
- Seramik / Cam / Plastik endüstrisi
- Emiş sistemleri
- Kutulama sistemleri
- Doldurma ve tartma sistemleri
- Havalandırma ve hava boşaltma sistemleri

### Çeşitli aseptik bağlantılarla girişler mümkün!

### Bağlantı seçenekleri:

- Flanş bağlantısı
- İç dişli bağlantısı G / NPT
- Tri-klamp
- Kaynak uçları
- Vida dişli ağız (süt borusu vida dişli)

Özel topraklamalı özel iletken tipler; 1, 2, 21 ve 22 Ex bölgelerinde kullanıma uygundur.

**VMC serisi pnömatik pinç vanaları 97/23/EG basınçlı cihazlar yönergelerinin tüm standartlarına uygundur.**

### Hammaddeler / Materyaller:

**Gövdeler:** Paslanmaz çelik 1.4408  
Alüminyum AlSi10Mg  
Plastik POM

**Bağlantı kapağı:** Paslanmaz çelik 1.4404  
Plastik POM

### Manşetler:

Sürtünmeye dayanıklı doğal kauçuk, Açık gıda maddesi için doğal kauçu, EPDM, Açık gıda maddesi için EPDM, nitril, Açık gıda maddesi için, nitril, hipalon, butil, neopren, silikon, viton diğerleri istek üzerine.

**Maks. işletme / malzeme basıncı:** ~ 6 bar

**Maks. kumanda / kapatma basıncı:** 8 bar

**Fark basıncı:** 2-3,5 bar

Çalışma genişliğine/elastomere göre değişir

### Industrial areas:

- Food/ pharmaceutical/ beverage industry
- Chemical industry
- Pneumatic conveying systems
- Pigments and granules
- Ceramics/ glass/ plastic industry
- Extraction systems
- Dosing systems
- Filling and weighing systems
- Air venting systems

### Connections with various aseptic connections available!

### Connection options:

- Flange Connection
- Internal Thread Connection G / NPT
- Tri-Clamp
- Weld-on ends
- Threaded spigot (RJT Connection)

Special, conductive models with a separate earthing system, which are suitable for use in areas at risk of explosions (EX) in zones 1, 2, 21 and 22 are also available.

**The air operated Pinch Valves of VMC series fulfill all requirements of the Pressure Equipment Directive 97/23/EC.**

### Materials:

**Body:** Stainless steel 1.4408  
Aluminium AlSi10Mg  
Plastic POM

**Socket Connection:** Stainless steel 1.4404  
Plastic POM

### Sleeves:

Natural rubber antiabrasive, Natural rubber food quality, EPDM, EPDM food quality, Nitrile, Nitrile food quality, Hypalon, Neoprene, Silicone, Viton, other materials on request.

**Operating / medium pressure max.:** ~ 6 bar

**Control / closing pressure max.:** 8 bar

**Differential pressure:** 2-3.5 bar  
varies depending on diameter / sleeve

# Pnömatik pinç vanası - Flanş bağlantısı

## Air operated Pinch Valve - Flange connection

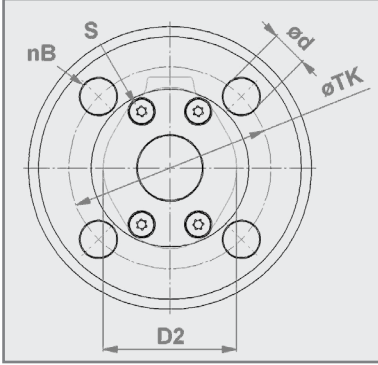

DN25 - DN80

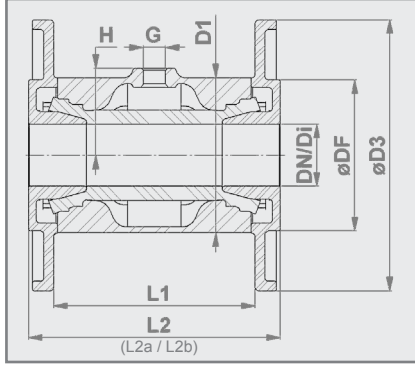

DN25 - DN50 \* DIN EN ISO 228 "G"

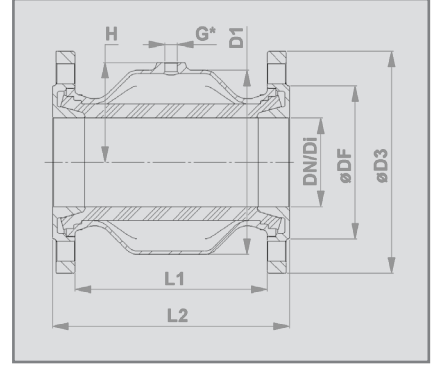

DN65 - DN80 \* DIN EN ISO 228 "G"

### Bağlantı tipi:

Flanş bağlantısı göre  
DIN EN 1092-1 PN 10/16

İstek üzerine DIN 11853-2 (L2a) / 11864-2 Şekil A (L2b)

### Connection type:

Flange connection according to  
DIN EN 1092-1 PN 10/16

DIN 11853-2 (L2a) / 11864-2 form A (L2b) on request

### Gövdeler:

- Paslanmaz çelik 1.4408 (E)
- Alüminyum AlSi10Mg (A)

### Body:

- Stainless steel 1.4408 (E)
- Aluminium AlSi10Mg (A)

### Flanşlar:

- Paslanmaz çelik 1.4404 (E)

### Flange:

- Stainless steel 1.4404 (E)

### Valf yüzeyi:

Paslanmaz çelik: Elektropolaj mat

Gıda maddeleri ile teması bulunan parçalar = Ra 0,5  
İstek üzerine mekanik polaj Ra 0,3.

Alüminyum: Toz kaplama 60-80µm RAL 9006

### Valve finish:

Stainless steel: Electropolished matt

Wetted parts = Ra 0.5

Satin polished (brushed) Ra 0.3 on request.

Aluminium: Powder coated 60-80µm RAL 9006

DN / Di (mm)	D1 (mm)	D2 (mm)	ø D3 (mm)	ø DF (mm)	nB	ø d (mm)	ø TK (mm)	L1 (mm)	L2 (mm)	L2a (mm)	L2b (mm)	G (inch)	H (mm)	<sup>1</sup> S	<sup>2</sup> Hacim (l) <sup>2</sup> vol. (l) (ca./approx.)	Ağırlık weight (kg) (EE)	Ağırlık weight (kg) (AE)
25	72	57	115	68	4	14	85	96	125	213	218	1/8"	36,5	4x(M6x35)	0,09	2,4	1,9
32	80	66	140	78	4	18	100	104	130	226	241	1/4"	45	8x(M6x35)	0,13	2,9	2,3
40	90	77	150	88	4	18	110	119	155	238	253	1/4"	50	8x(M6x35)	0,22	4,0	3,1
50	110	88	165	106	4	18	125	149	185	264	279	1/4"	60	8x(M6x35)	0,36	5,8	4,4
65	139	102	185	122	4	18	145	133	170	267	327	1/4"	73,5	8x(M10x20)	0,44	5,5	4,5
80	172	126	200	138	4	18	160	173	213	309	373	1/4"	90	8x(M10x20)	0,88	7,5	5,3

<sup>1</sup> Delik sayısı / Number of holes

<sup>1</sup> Montaj civataları (Paslanmaz çelik 1.4401 / AISI 316) göre DIN 7985 / mounting screws (stainless steel 1.4401 / AISI 316) according to DIN 7985

<sup>2</sup> Hacim = Manşet kapalı durumda kumanda medyası hacmi / Volume = Control volume with closed sleeve

## Pnömatik pinç vanası - İç dişli bağlantısı

## Air operated Pinch Valve - Internal Thread connection

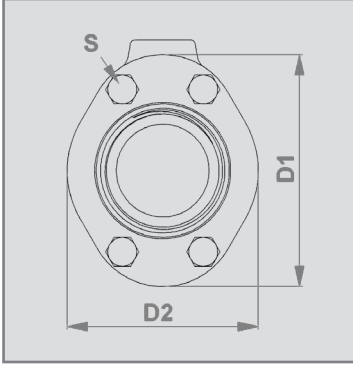

DN10 - DN50

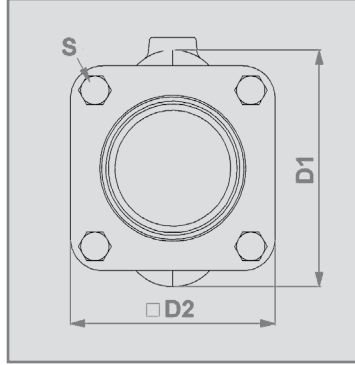

DN65 - DN80

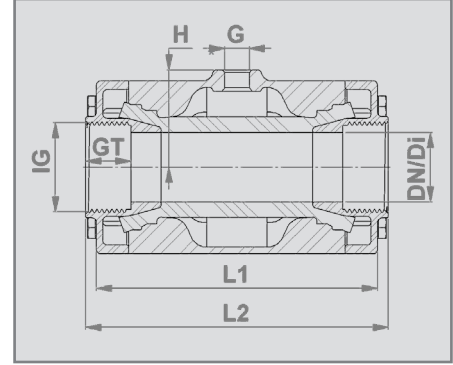

\* DIN EN ISO 228 "G"

### Bağlantı tipi:

İç dişli bağlantısı göre  
DIN EN ISO 228 "G" veya  
ANSI/ASME B1.20.1 "NPT"

### Connection type:

Internal Thread Connection according to  
DIN EN ISO 228 "G" or  
ANSI/ASME B1.20.1 "NPT"

### Gövdeler:

- DN10-80: Paslanmaz çelik 1.4408 (E)
- DN20-80: Alüminyum AlSi10Mg (A)
- DN10-15: Plastik POM doğal (P)
- DN10-15: Plastik POM iletken (P) 

### Body:

- DN 10-80: Stainless steel 1.4408 (E)
- DN 20-80: Aluminium AlSi10Mg (A)
- DN 10-15: Plastic POM (P) natural white
- DN 10-15: Plastic POM (P) conductive 

### Vida dişi kapağı:

- DN10-80: Paslanmaz çelik 1.4404 (E)
- DN20-50: Plastik POM doğal (P),  
gıda maddesi için uygunluğu onaylanmış
- DN20-50: Plastik POM iletken (P)   
patlama tehlikesi olan alanlar için

### (Internal Thread) Socket ends:

- DN 10-80: Stainless steel 1.4404 (E)
- DN 20-50: Plastic POM (P) natural white
- DN 20-50: Plastic POM (P) conductive  
for hazardous areas 

### Valf yüzeyi:

Paslanmaz çelik: Elektropolaj mat

### Valve finish:

Stainless steel: Electropolished matt

Alüminyum: Toz kaplama 60-80µm RAL 9006

Aluminium: Powder coated 60-80µm RAL 9006

DN / Di (mm)	D1 (mm)	D2 (mm)	IG (inch)	GT (mm)	L1 (mm)	L2 (mm)	G (inch)	H (mm)	<sup>1</sup> S	<sup>2</sup> Hacim (l) <sup>2</sup> vol. (l) (ca./approx)	Ağırlık weight (kg) (EE)	Ağırlık weight (kg) (AE)	Ağırlık weight (kg) (AP)	Ağırlık weight (kg) (PE)
10	46	35	G $\frac{3}{8}$ "	12	68	80	1/8"	23	4x(M6x16)	0,03	0,5	-	-	0,3
15	56	47	G $\frac{1}{2}$ "	15	85	95	1/8"	28	4x(M6x20)	0,05	0,8	-	-	0,4
20	62	49	G $\frac{3}{4}$ "	17	93	103	1/8"	31,5	4x(M6x25)	0,07	0,9	0,6	0,4	-
25	72	57	G1"	20	110	120	1/8"	36,5	4x(M6x30)	0,09	1,4	0,8	0,5	-
32	80	66	G1 $\frac{1}{4}$ "	21	130	140	1/4"	45	8x(M6x35)	0,13	1,8	1,2	0,9	-
40	90	77	G1 $\frac{1}{2}$ "	21	150	160	1/4"	50	8x(M6x35)	0,22	2,4	1,5	1,1	-
50	110	88	G2"	25	175	185	1/4"	60	8x(M6x35)	0,36	3,6	2,2	1,6	-
65	139	115	G2 $\frac{1}{2}$ "	30	173	200	1/4"	73,5	8x(M10x35)	0,44	3,7	3,0	-	-
80	172	133	G3"	33	213	230	1/4"	90	8x(M10x35)	0,88	5,5	4,4	-	-

<sup>1</sup> Montaj civataları (Paslanmaz çelik 1.4401 / AISI 316) göre DIN 933 (EN24107) / mounting screws (stainless steel 1.4401 / AISI 316) according to DIN 933 (EN24107)

<sup>2</sup> Hacim = Manşet kapalı durumda kumanda medyası hacmi / Volume = Control volume with closed sleeve

\* Alternatif olarak K tipimiz mevcuttur → Montaj uzunluğu = 150mm / Alternatively available is our K-variant → length = 150mm

Teknik değişiklik hakkı saklıdır.

Technical details subject to change without notice.

# Pnömatik pinç vanası - Tri-klamp bağlantısı

## Air operated Pinch Valve - Tri-Clamp connection

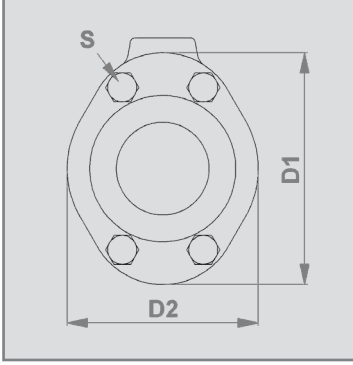

DN10 - DN50

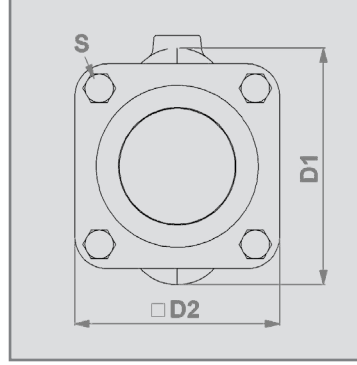

DN65 - DN80

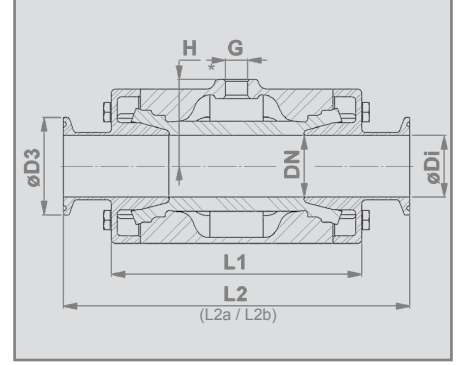

\* DIN EN ISO 228 "G"

### Bağlantı tipi:

Tri-klamp göre DIN 32676

İstek üzerine DIN 11853-3 (L2a) / 11864-3 Şekil A (L2b)

### Connection type:

Tri-Clamp according to DIN 32676

DIN 11853-3 (L2a) / 11864-3 form A (L2b) on request

### Gövdeler:

- DN10-80: Paslanmaz çelik 1.4408 (E)
- DN20-80: Alüminyum AISi10Mg (A)
- DN10-15: Plastik POM doğal (P)
- DN10-15: Plastik POM iletken (P) 

### Body:

- DN 10-80: Stainless steel 1.4408 (E)
- DN 20-80: Aluminium AISi10Mg (A)
- DN 10-15: Plastic POM (P) natural white
- DN 10-15: Plastic POM (P) conductive 

### Tri-klamp:

- DN10-80: Paslanmaz çelik 1.4404 (E)

### Tri-Clamp Connection:

- DN 10-80: Stainless steel 1.4404 (E)

### Valf yapı uzunluğu:

DN10: DIN EN 558 serisi 27

DN15-50: DIN EN 558 serisi 1

DN65-80: DIN EN 558 serisi 7

### Valve face to face length:

DN 10: Acc. to DIN EN 558 row 27

DN 15-50: Acc. to DIN EN 558 row 1

DN 65-80: Acc. to DIN EN 558 row 7

### Valf yüzeyi:

Paslanmaz çelik: Elektropolaj mat

Gıda maddeleri ile teması bulunan parçalar = Ra 0,5

İstek üzerine mekanik polaj Ra 0,3.

### Valve finish:

Stainless steel: Electropolished matt

Wetted parts = Ra 0,5

Satin polished (brushed) Ra 0.3 on request.

Alüminyum: Toz kaplama 60-80µm RAL 9006

Aluminium: Powder coated 60-80µm RAL 9006

DN (mm)	ø Di (mm)	D1 (mm)	D2 (mm)	ø D3 (mm)	L1 (mm)	L2 (mm)	L2a (mm)	L2b (mm)	G (inch)	H (mm)	<sup>1</sup> S	<sup>2</sup> Hacim (l) <sup>2</sup> vol. (l) (ca./approx.)	Ağırlık weight (kg) (EE)	Ağırlık weight (kg) (AE)	Ağırlık weight (kg) (PE)
10	10	46	35	34	80	115	162	190	1/8"	23	4x(M6x16)	0,03	0,5	-	0,3
15	16	56	47	34	95	130	187	215	1/8"	28	4x(M6x20)	0,05	0,9	-	0,5
20	20	62	49	34	103	150	199	227	1/8"	31	4x(M6x25)	0,07	1,0	0,6	-
25	26	72	57	50,50	120	160	212	241	1/8"	36	4x(M6x30)	0,09	1,5	1,0	-
32	32	80	66	50,50	140	180	229	267	1/4"	45	8x(M6x35)	0,13	1,9	1,3	-
40	38	90	77	50,50	160	200	241	279	1/4"	50	8x(M6x35)	0,22	2,6	1,7	-
50	50	110	88	64	185	230	268	304	1/4"	60	8x(M6x35)	0,36	3,9	2,5	-
65	65	139	115	91	173	216	272	332	1/4"	73,5	8x(M10x35)	0,44	4,0	3,3	-
80	80	172	133	106	213	254	314	374	1/4"	90	8x(M10x35)	0,88	5,8	4,7	-

<sup>1</sup> Montaj civataları (Paslanmaz çelik 1.4401 / AISI 316) göre DIN 933 (EN24107) / mounting screws (stainless steel 1.4401 / AISI 316) according to DIN 933 (EN24107)

<sup>2</sup> Hacim = Manşet kapalı durumda Kumanda medyası hacmi / Volume = Control volume with closed sleeve

# Pnömatik pinç vanası - Kaynak uçları

## Air operated Pinch Valve - Weld-on ends

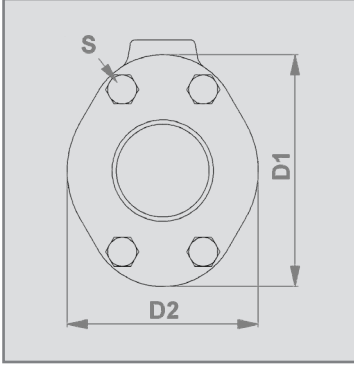

DN10 - DN50

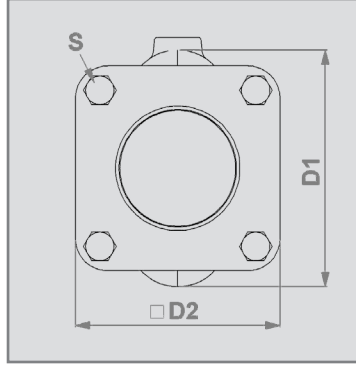

DN65 - DN80

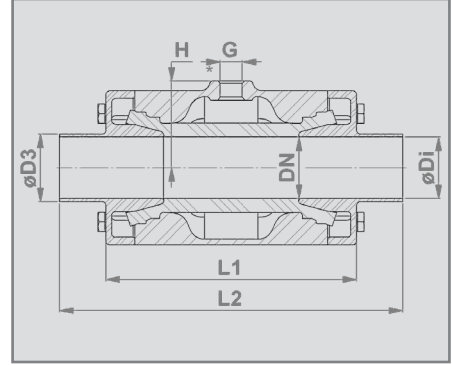

\* DIN EN ISO 228 "G"

### Bağlantı tipi:

Kaynak uçları göre DIN 11850 serisi 2

### Connection type:

Weld-on ends according to DIN 11850 row 2

### Gövdeler:

- DN10-80: Paslanmaz çelik 1.4408 (E)
- DN20-80: Alüminyum AISi10Mg (A)
- DN10-15: Plastik POM doğal (P)
- DN10-15: Plastik POM iletken (P) 

### Body:

- DN 10-80: Stainless steel 1.4408 (E)
- DN 20-80: Aluminium AISi10Mg (A)
- DN 10-15: Plastic POM (P) natural white
- DN 10-15: Plastic POM (P) conductive 

### Kaynak uçları:

- DN10-80: Paslanmaz çelik 1.4404 (E)

### Weld-on ends:

- DN 10-80: Stainless steel 1.4404 (E)

### Valf yapı uzunluğu:

DN10: DIN EN 558 serisi 27  
 DN15-50: DIN EN 12982 serisi 61  
 DN65-80: DIN EN 558 serisi 7

### Valve face to face length:

DN 10: Acc. to DIN EN 558 row 27  
 DN 15-50: Acc. to DIN EN 12982 row 61  
 DN 65-80: Acc. to DIN EN 558 row 7

### Valf yüzeyi:

Paslanmaz çelik: Elektropolaj mat

Gıda maddeleri ile teması bulunan parçalar = Ra 0,5  
 İstek üzerine mekanik polaj Ra 0,3.

### Valve finish:

Stainless steel: Electropolished matt

Wetted parts = Ra 0.5  
 Satin polished (brushed) Ra 0.3 on request.

Alüminyum: Toz kaplama 60-80µm RAL 9006

Aluminium: Powder coated 60-80µm RAL 9006

DN (mm)	ø Di (mm)	D1 (mm)	D2 (mm)	ø D3 (mm)	L1 (mm)	L2 (mm)	G (inch)	H (mm)	'S	<sup>2</sup> Hacim (l) <sup>2</sup> vol. (l) (ca./approx.)	Ağırlık weight (kg) (EE)	Ağırlık weight (kg) (AE)	Ağırlık weight (kg) (PE)
10	10	46	35	13x1,5	68	115	1/8"	23	4x(M6x16)	0,03	0,5	-	0,3
15	16	56	47	19x1,5	85	140	1/8"	28	4x(M6x20)	0,05	0,8	-	0,5
20	20	62	49	23x1,5	93	152	1/8"	31	4x(M6x25)	0,07	1,0	0,6	-
25	26	72	57	29x1,5	110	165	1/8"	36	4x(M6x30)	0,09	1,4	0,9	-
32	32	80	66	35x1,5	130	178	1/4"	45	8x(M6x35)	0,13	1,9	1,3	-
40	38	90	77	41x1,5	150	190	1/4"	50	8x(M6x35)	0,22	2,5	1,6	-
50	50	110	88	53x1,5	175	216	1/4"	60	8x(M6x35)	0,36	3,8	2,5	-
65	65	139	115	70x2	173	216	1/4"	73,5	8x(M10x35)	0,44	3,8	3,1	-
80	80	172	133	85x2	213	256	1/4"	90	8x(M10x35)	0,88	5,6	4,5	-

<sup>1</sup> Montaj civataları (Paslanmaz çelik 1.4401 / AISI 316) göre DIN 933 (EN24107) / mounting screws (stainless steel 1.4401 / AISI 316) according to DIN 933 (EN24107)

<sup>2</sup> Hacim = Manşet kapalı durumda kumanda medyası hacmi / Volume = Control volume with closed sleeve

# Pnömatik pinç vanası - Vida dişli ağız

## Air operated Pinch Valve - Threaded spigot

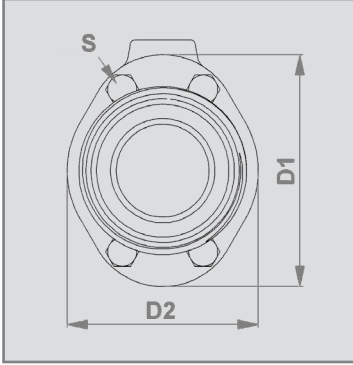

DN10 - DN50

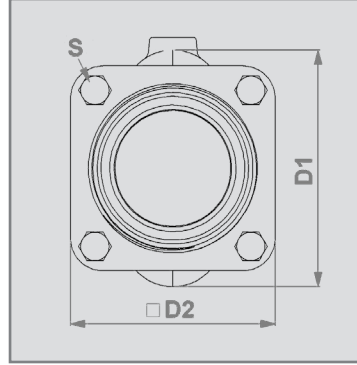

DN65 - DN80

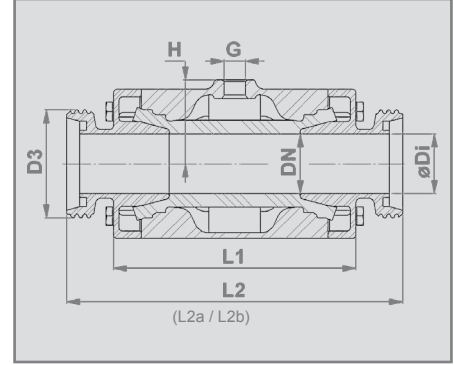

\* DIN EN ISO 228 "G"

### Bağlantı tipi:

Vida dişli ağız göre DIN 11851  
İstek üzerine DIN 11853-1 (L2a) / 11864-1 Şekil A (L2b)

### Connection type:

Threaded spigot according to DIN 11851  
DIN 11853-1 (L2a) / 11864-1 form A (L2b) on request

### Gövdeler:

- DN10-80: Paslanmaz çelik 1.4408 (E)
- DN20-80: Alüminyum AISi10Mg (A)
- DN10-15: Plastik POM doğal (P)
- DN10-15: Plastik POM iletken (P) 

### Body:

- DN 10-80: Stainless steel 1.4408 (E)
- DN 20-80: Aluminium AISi10Mg (A)
- DN 10-15: Plastic POM (P) natural white
- DN 10-15: Plastic POM (P) conductive 

### Vida dişli ağız:

- DN10-80: Paslanmaz çelik 1.4404 (E)

### Threaded spigot:

- DN 10-80: Stainless steel 1.4404 (E)

### Valf yapı uzunluğu:

DN10: DIN EN 558 serisi 27  
DN15-50: DIN EN 558 serisi 1

### Valve face to face length:

DN 10: Acc. to DIN EN 558 row 27  
DN 15-50: Acc. to DIN EN 558 row 1

### Valf yüzeyi:

Paslanmaz çelik: Elektropolaj mat

Gıda maddeleri ile teması bulunan parçalar = Ra 0,5  
İstek üzerine mekanik polaj Ra 0,3.

### Valve finish:

Stainless steel: Electropolished matt

Wetted parts = Ra 0,5  
Satin polished (brushed) Ra 0.3 on request.

Alüminyum: Toz kaplama 60-80µm RAL 9006

Aluminium: Powder coated 60-80µm RAL 9006

DN (mm)	ø Di (mm)	D1 (mm)	D2 (mm)	D3	G (inch)	H (mm)	L1 (mm)	L2 (mm)	L2a (mm)	L2b (mm)	<sup>1</sup> S	<sup>2</sup> Hacim (l) <sup>2</sup> vol. (l) (ca./approx.)	Ağırlık weight (kg) (EE)	Ağırlık weight (kg) (AE)	Ağırlık weight (kg) (PE)
10	10	46	35	Rd28x1/8"	1/8"	23	68	115	153	197	4x(M6x16)	0,03	0,5	-	0,3
15	16	56	47	Rd34x1/8"	1/8"	28	85	130	178	222	4x(M6x20)	0,05	0,9	-	0,5
20	20	62	49	Rd44x1/6"	1/8"	31	93	150	194	238	4x(M6x25)	0,07	1,1	0,8	-
25	26	72	57	Rd52x1/6"	1/8"	36	110	160	217	251	4x(M6x30)	0,09	1,6	1,1	-
32	32	80	66	Rd58x1/6"	1/4"	45	130	180	238	274	8x(M6x35)	0,13	2,1	1,5	-
40	38	90	77	Rd65x1/6"	1/4"	50	150	200	252	286	8x(M6x35)	0,22	2,8	1,9	-
50	50	110	88	Rd78x1/6"	1/4"	60	175	230	278	312	8x(M6x35)	0,36	4,2	2,9	-
65	65	139	115	Rd95x1/6"	1/4"	73,5	173	266	336	336	8x(M10x35)	0,44	4,5	3,8	-
80	80	172	133	Rd110x1/6"	1/4"	90	213	304	382	382	8x(M10x35)	0,88	6,7	5,6	-

<sup>1</sup> Montaj civataları (Paslanmaz çelik 1.4401 / AISI 316) göre DIN 933 (EN24107) / mounting screws (stainless steel 1.4401 / AISI 316) according to DIN 933 (EN24107)

<sup>2</sup> Hacim = Manşet kapalı durumda kumanda medyası hacmi / Volume = Control volume with closed sleeve